

METALLIZED POLYESTER FILM CAPACITOR WITH INTEGRATED CERAMIC VARISTOR

Typical applications: these component units are used to reduce transient phenomena and act as EMI-RFI suppressors for automotive motors and other suppression applications.

- Engine blower fans
- Heating/air-conditioning blowers
- Electric window regulators
- Electric windshield wipers
- Central locking systems
- Electric sun roofs
- Fuel/oil pumps
- Electrically operated seats

Ød ±0.05	p = 5mm	p = 10mm
	0.6	0.7

PRODUCT CODE: **F5A**

Pitch (mm)	Box thickness (B) (mm)	Maximum dimensions (mm)		
		B max	H max	L max
5.0	<5.0	B +0.1	H +0.1	L +0.2
5.0	≥5.0	B +0.1	H +0.1	L +0.3
10.0		B +0.2	H +0.1	L +0.35

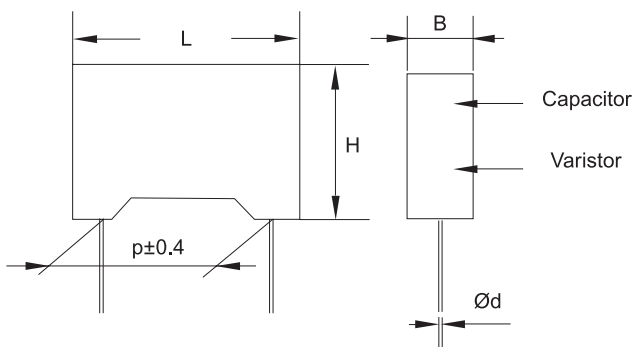

Circuit diagram

The F5A Series was designed for different suppression conditions and peak voltage limitation. Different operating and clamping voltages allow an optimal adaption to the different application requirements. Best results for suppression purposes are achieved by using low inductive MKT capacitors in parallel construction with ceramic varistor in one single case. The leaded EMI-RFI suppression element F5A is mainly prepared for Automotive applications without PC-board (e.g. motor suppression) or mixed leaded and SMD PC-boards. Upon customer's request there is also the possibility to create and deliver special versions.

PRODUCT CODE SYSTEM

The part number, comprising 14 digits, is formed as follows:

1	2	3	4	5	6	7	8	9	10	11	12	13	14
F	5	A										-	

- Digit 1 to 3 Series code.
- Digit 4 d.c. Rated voltage:
A = 5V B = 18V H = 25V J = 30V
N = 45V C = 50V D = 63V
- Digit 5 Pitch (mm): C=5; F=10
- Digit 6 to 9 Digits 7 - 8 - 9 indicate the first three digits of Capacitance value and the 6th digit indicates the number of zeros that must be added to obtain the Rated Capacitance in pF.
- Digit 10 to 11 Mechanical version and/or packaging (Table 1)
- Digit 12 Varistor voltage (Table 2).
- Digit 13 Size code
- Digit 14 Capacitance tolerance:
J=5%; K=10%; M=20%.

GENERAL CHARACTERISTICS

- Capacitor:** metallized polyester film (MKT).
- Varistor:** metal oxide with silver palladium plates.
- Protection:** plastic case, thermosetting resin filled. Box material is solvent resistant and flame retardant according to UL 94 V0.
- Leads:** tinned wire.
- Marking:** Manufacturer's logo (only pitch 10mm), series (F5A), capacitance, tolerance, D.C. rated voltage, manufacturing date code.

Climatic category: 55/125/56 IEC 60068-1

Operating temperature range: -55 to +125°C

Table 1 Packaging

Standard packaging style	Lead length (mm)	Taping style			Ordering code (Digit 10 to 11)
		P ₂ (mm)	Fig. (No)	Pitch (mm)	
AMMO-PACK		6.35	1	5	DQ
AMMO-PACK		1.27	2	10	DQ
REEL Ø 355mm		6.35	1	5	CK
REEL Ø 500mm		1.27	2	10	CK
Loose, short leads	4 ⁺²				AA
Loose, long leads	17 ^{+1/-2}				Z3

Other packaging styles are available upon request.

METALLIZED POLYESTER FILM CAPACITOR WITH INTEGRATED CERAMIC VARISTOR

PRODUCT CODE: **F5A**

ELECTRICAL CHARACTERISTICS

Capacitance range: 0.1µF to 3.3µF (see Table 3)
Capacitance values: E12 series (IEC 60063 Norm).
Capacitance tolerance: ±5% (J); ±10% (K); ±20% (M).
Rated voltage (V_R): 5Vdc - 15Vdc - 25Vdc - 30Vdc - 45Vdc - 50Vdc - 63Vdc

Temperature derated voltage:
 for temperature over 100°C a decreasing factor of 2% per degree has to be applied on the rated voltage V_R.

Varistor voltage (V_V): 1mA (see Table 2) tol. ±10%
Varistor voltage range: 8Vdc to 82Vdc
V_{RMS} range: 4Vac to 50Vac
Clamping voltage (V_C): 1A; 8/20µs (see Table 2).
Peak current (I_P): 8/20µs (see Table 2).
Transient Energy (W_P): max (2ms) (see Table 2).
Power dissipation (P_{max}): 0.008W

Leakage current (I_{dc}): ≤50µA @ V_R

Dissipation Factor (D.F.):
 tgδ x 10⁻⁴ at 25°C ±5°C

kHz	tgδ x 10 ⁻⁴
1	80
100	300

Table 2 **Voltage and energy**

Digit 4		Digit 12		V _{RMS} (Vac)	V _C (V)	W _P (J)	I _P (A)
letter	V _R (Vdc)	letter	V _V (Vdc)				
A	5	B	8	4	17	0.3	150
		E	11	6	25	0.4	200
		I	15	8	30	0.5	200
B	18	B	22	14	38	0.5	200
		E	27	17	44	0.6	200
H	25	A	33	20	54	0.7	200
J	30	D	39	25	65	1.0	200
		I	47	30	77	1.0	200
N	45	B	56	35	90	0.4	100
C	50	C	68	40	110	0.5	100
D	63	C	82	50	135	0.6	100

Table 3 **Capacitance and size**

Rated Cap. (µF)	Rated Voltage (V _R)	Size code	Size (Std dimensions)			
			B	H	L	p
0.1 to 0.47	5 to 63	5	4.5	9.5	7.2	5.0
0.56 to 1.5	5 to 63	6	5.0	10.0	7.2	5.0
1.8 to 2.2	5 to 63	7	6.0	11.0	7.2	5.0
0.1 to 1.0	5 to 63	2	5.0	11.0	13.0	10.0
1.2 to 1.5	5 to 63	3	6.0	12.0	13.0	10.0

All dimensions are in mm.

TEST METHOD AND PERFORMANCE

Damp heat, steady state:

Test conditions

Temperature: +40°C±2°C
 Relative humidity (RH): 93% ±2%
 Test duration: 56 days

Performance

Capacitance change |ΔC/C|: ≤5%
 Varistor voltage change: ≤10%
 DF change (Δtgδ): ≤50x10⁻⁴ @ 1kHz
 Leakage current at V_R: ≤100µA

Endurance:

Test conditions

Temperature: +125°C±2°C / 100°C±2°C
 Voltage applied: 0.5xV_R / 1.0xV_R
 Test duration: 1000 h

Performance

Capacitance change |ΔC/C|: ≤10%
 Varistor voltage change: ≤10%
 DF change (Δtgδ): ≤50x10⁻⁴ @ 1kHz
 Leakage current at V_R: ≤100µA

Resistance to soldering heat:

Test conditions

Temperature: +260°C±5°C
 Test duration: 10±1s

Performance

Capacitance change |ΔC/C|: ≤3%
 Varistor voltage change: ≤5%
 DF change (Δtgδ): ≤30x10⁻⁴ @ 1kHz
 Leakage current at V_R: ≤50µA

Peak current derating:

Test conditions

Reference CECC 42000 / test C 2.1;
 Test duration: 100 times (2ms)
 Time between each current peak: 120s

Performance

Capacitance change |ΔC/C|: ≤10%
 Varistor voltage change: ≤10%
 DF change (Δtgδ): ≤30x10⁻⁴ @ 1kHz
 Leakage current at V_R: ≤100µA

Long term stability (after two years):

Test conditions

Temperature: -40°C to +80°C
 Humidity: ≤70%

Performance

Capacitance change |ΔC/C|: ≤3%
 Varistor voltage change: ≤5%
 DF change (Δtgδ): ≤20x10⁻⁴ @ 1kHz
 Leakage current at V_R: ≤50µA

Reliability:

Reference MIL HDB 217

Application conditions:

Temperature: +40°C±2°C
 Voltage: 0.5xV_R
 Failure rate: ≤2 FIT
 (1FIT = 1x10⁻⁹ failures/componentsxh)

Failure criteria:

Capacitance change |ΔC/C|: >10%
 Varistor voltage change: >10%
 DF change (Δtgδ): ≤20x10⁻⁴ @ 1kHz
 Leakage current at V_R: ≤200µA

Warning: the component F5A is a protection and suppression combined passive component. Strong overloading (much higher energy, current or voltage) can strongly damage the component with the risk of explosion and fire.