

## Aluminum Capacitors SMD (Chip) Long Life

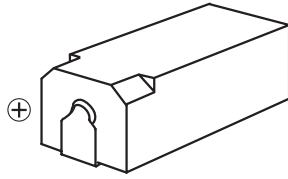

Fig.1 Component outlines



### FEATURES

- Polarized aluminum electrolytic capacitors, non-solid electrolyte, self healing.
- Extended voltage and capacitance range.
- SMD-version, fully moulded, insulated.
- Flexible terminals, reflow and wave solderable.
- Compact, rectangular shape.
- Charge and discharge proof, no peak current limitation.
- Supplied in blister tape on reel.

### APPLICATIONS

- SMD technology.
- Industrial and professional applications.
- Telecommunications, automotive, EDP general industrial.
- Coupling, decoupling, smoothing, filtering, buffering, timing.

### MARKING

- Rated capacitance (in  $\mu\text{F}$ ).
- Rated voltage (in V).
- Date code in accordance with IEC 60062.
- Name of manufacturer.
- ‘-’ sign indicating the cathode. The anode is identified by bevelled edges.
- Series number (139).

QUICK REFERENCE DATA	
DESCRIPTION	VALUE
Nominal case sizes (L x W x H in mm)	14.3 x 6.2 x 6.9 and 14.3 x 7.6 x 8.2
Rated capacitance range, $C_R$	1.0 to 220 $\mu\text{F}$
Tolerance on $C_R$	$\pm 20\%$
Rated voltage range, $U_R$	6.3 to 100 V
Category temperature range	-55 to +105°C
Endurance test at 105 °C	1000 hours
Useful life at 105 °C	2000 hours
Useful life at 40 °C ; 1.3 x $I_R$ applied	200000 hours
Shelf life at 0 V, 105 °C	500 hours
Resistance to soldering heat test	immersion in solder: 10 s at 260 °C or 40 s at 215 °C
Based on sectional specification	IEC 60384-18/CECC 32300
Climatic category IEC 60068	55/105/56

SELECTION CHART FOR $C_R$ , $U_R$ AND RELEVANT NOMINAL CASE SIZES (L x W x H in mm)								
$C_R$ ( $\mu\text{F}$ )	$U_R$ (V)							
	6.3	10	16	25	40	50	63	100
1.0	-	-	-	-	-	-	-	14.3 x 6.2 x 6.9
2.2	-	-	-	-	-	-	14.3 x 6.2 x 6.9	14.3 x 6.2 x 6.9
3.3	-	-	-	-	-	-	14.3 x 6.2 x 6.9	14.3 x 7.6 x 8.2
4.7	-	-	-	-	-	-	14.3 x 6.2 x 6.9	14.3 x 7.6 x 8.2
10	-	-	-	14.3 x 6.2 x 6.9	-	14.3 x 6.2 x 6.9	14.3 x 7.6 x 8.2	-
15	-	-	-	-	14.3 x 6.2 x 6.9	14.3 x 7.6 x 8.2	-	-
22	-	-	-	14.3 x 6.2 x 6.9	-	14.3 x 7.6 x 8.2	-	-

SELECTION CHART FOR C <sub>R</sub> , U <sub>R</sub> AND RELEVANT NOMINAL CASE SIZES (L x W x H in mm)								
C <sub>R</sub> (μF)	U <sub>R</sub> (V)							
	6.3	10	16	25	40	50	63	100
33	-	-	-	14.3 × 6.2 × 6.9	14.3 × 7.6 × 8.2	-	-	-
47	-	-	14.3 × 6.2 × 6.9	14.3 × 7.6 × 8.2	-	-	-	-
68	-	14.3 × 6.2 × 6.9	-	-	-	-	-	-
100	14.3 × 6.2 × 6.9	-	14.3 × 7.6 × 8.2	-	-	-	-	-
150	-	14.3 × 7.6 × 8.2	-	-	-	-	-	-
220	14.3 × 7.6 × 8.2	-	-	-	-	-	-	-

**DIMENSIONS** in millimeters

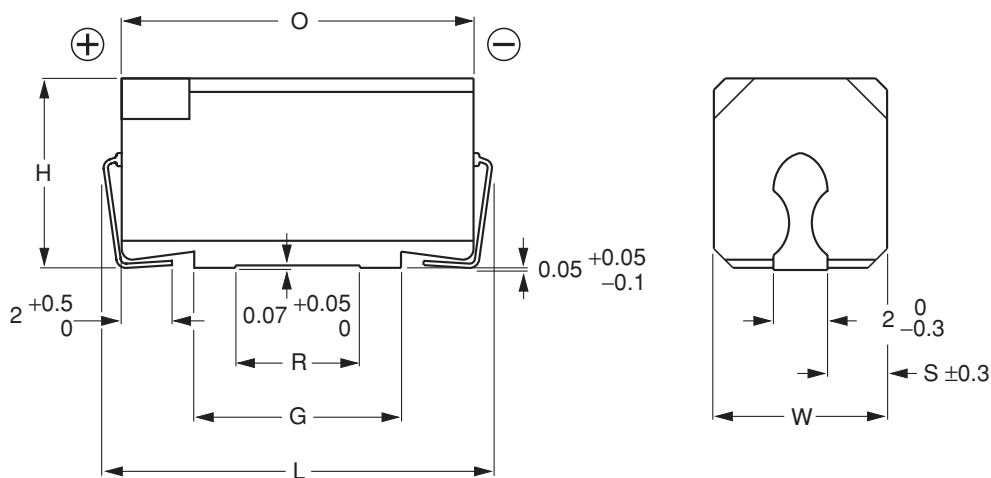

Fig.2 Dimensional outline.

Table 1

DIMENSIONS in millimeters, MASS AND PACKAGING QUANTITIES										
NOMINAL CASE SIZE L × W × H	CASE CODE	L <sub>max</sub>	W <sub>max</sub>	H <sub>max</sub>	O <sub>max</sub>	S	G <sub>max</sub>	R <sub>min</sub>	MASS (g)	PACKAGING QUANTITIES PER REEL
14.3 × 6.2 × 6.9	2	14.5	6.3	7.05	13.0	2.15	7.5	4.7	≈0.95	700
14.3 × 7.6 × 8.2	3	14.5	7.7	8.35	13.0	2.85	7.5	4.7	≈1.3	700

**Note**

- Detailed tape dimensions see section 'PACKAGING'.

Table 2

RECOMMENDED SOLDERING PAD DIMENSIONS in millimeters (placement accuracy ±0.25mm)														
NOMINAL CASE SIZE L × W × H	FOR REFLOW SOLDERING							FOR WAVE SOLDERING						
	A	B	C	D	E	F	G	A	B	C	D	E	F	G
14.3 × 6.2 × 6.9	15.8	8.8	3.5	2.8	8.0	16.2	7.7	18.6	10.0	4.3	5.0	8.8	20.5	11.5
14.3 × 7.6 × 8.2	15.8	8.8	3.5	2.8	8.0	16.2	9.1	18.6	10.0	4.3	6.0	8.8	21.5	13.0

**MOUNTING**

The capacitors are designed for automatic placement on to printed-circuit boards or hybrid circuits.

Optimum dimensions of soldering pads depend amongst others on soldering method, mounting accuracy, print lay-out and/or adjacent components.

For recommended soldering pad dimensions, refer to Fig.3 and Table 2.

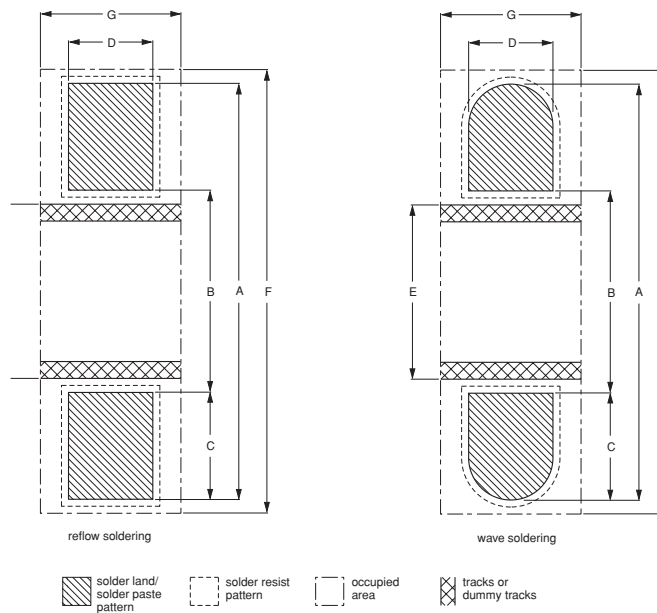

Fig.3 Recommended pad dimensions for reflow and wave soldering.

**SOLDERING**

Soldering conditions are defined by the curve, temperature versus time, where the temperature is that measured on the soldering pad during processing.

For maximum conditions of different soldering methods see Figs 4, 5 and 6.

Any temperature versus time curve which does not exceed the specified maximum curves may be applied.

AS A GENERAL PRINCIPLE, TEMPERATURE AND DURATION SHALL BE THE **MINIMUM** NECESSARY REQUIRED TO ENSURE GOOD SOLDERING CONNECTIONS. HOWEVER, THE SPECIFIED MAXIMUM CURVES SHOULD NEVER BE EXCEEDED.

Table 3

CURING CONDITIONS FOR SMD-GLUE	
MAX. T <sub>amb</sub> (°C)	MAX. EXPOSURE TIME (minutes)
125	30
140	10
150	5
160	2

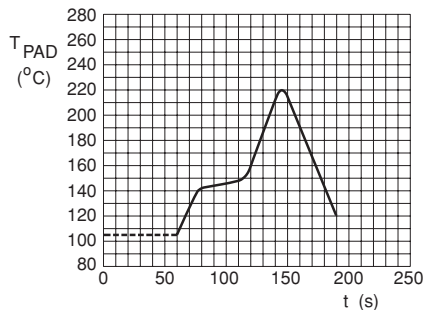

Fig.4 Maximum temperature load during infrared reflow soldering.

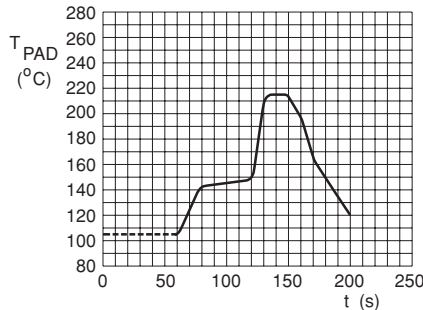

Fig.5 Maximum temperature load during vapour phase reflow soldering.

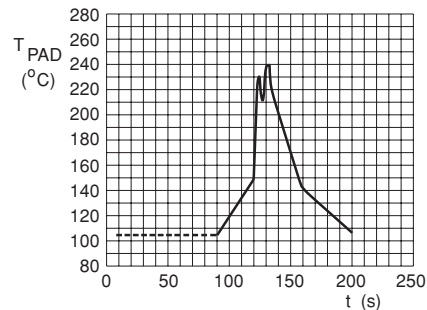

Fig.6 Maximum temperature load during (double-) wave soldering.

ELECTRICAL DATA	
SYMBOL	DESCRIPTION
$C_R$	rated capacitance at 100 Hz , tolerance $\pm 20\%$
$I_R$	rated RMS ripple current at 100 Hz ,105 °C
$I_{L5}$	max. leakage current after 5 minutes at $U_R$
Tan $\delta$	max. dissipation factor at 100 Hz
Z	max. impedance at 10 kHz

**ORDERING EXAMPLE**

Electrolytic capacitor 139 series  
 100  $\mu F$ /16 V;  $\pm 20\%$   
 Nominal case size: 14.3  $\times$  7.6  $\times$  8.2 mm; taped on reel  
 Catalog number: 2222 139 65101.

**Note**

1. Unless otherwise specified, all electrical values in Table 4 apply at  $T_{amb} = 20\text{ }^\circ\text{C}$ ,  $P = 86$  to  $106\text{ kPa}$ ,  $RH = 45$  to  $75\%$ .

Table 4

ELECTRICAL DATA AND ORDERING INFORMATION							
$U_R$ (V)	$C_R$ 100 Hz ( $\mu F$ )	NOMINAL CASE SIZE L $\times$ W $\times$ H (mm)	$I_R$ 100 Hz 105 °C (mA)	$I_{L5}$ 5 min ( $\mu A$ )	Tan $\delta$ 100 Hz	Z 10 kHz ( $\Omega$ )	CATALOG NUMBER 2222 139 .....
6.3	100	14.3 $\times$ 6.2 $\times$ 6.9	79	4.3	0.24	3.0	63101
	220	14.3 $\times$ 7.6 $\times$ 8.2	120	5.8	0.24	1.4	63221
10	68	14.3 $\times$ 6.2 $\times$ 6.9	71	4.4	0.20	2.9	64689
	150	14.3 $\times$ 7.6 $\times$ 8.2	110	6.0	0.20	1.3	64151
16	47	14.3 $\times$ 6.2 $\times$ 6.9	66	4.5	0.16	3.4	65479
	100	14.3 $\times$ 7.6 $\times$ 8.2	100	6.2	0.16	1.6	65101
25	10	14.3 $\times$ 6.2 $\times$ 6.9	40	3.5	0.09	12	66109
	22	14.3 $\times$ 6.2 $\times$ 6.9	48	4.1	0.14	5.5	66229
	33	14.3 $\times$ 6.2 $\times$ 6.9	59	4.7	0.14	3.7	66339
	47	14.3 $\times$ 7.6 $\times$ 8.2	79	5.4	0.14	2.6	66479
40	15	14.3 $\times$ 6.2 $\times$ 6.9	45	4.2	0.11	6	67159
	33	14.3 $\times$ 7.6 $\times$ 8.2	75	5.6	0.11	2.7	67339
50	10	14.3 $\times$ 6.2 $\times$ 6.9	40	4.0	0.09	7	61109
	15	14.3 $\times$ 7.6 $\times$ 8.2	56	4.5	0.09	4.7	61159
	22	14.3 $\times$ 7.6 $\times$ 8.2	67	5.2	0.09	3.2	61229

<b>ELECTRICAL DATA AND ORDERING INFORMATION</b>							
$U_R$ (V)	$C_R$ 100 Hz ( $\mu\text{F}$ )	NOMINAL CASE SIZE $L \times W \times H$ (mm)	$I_R$ 100 Hz 105 °C (mA)	$I_{L5}$ 5 min ( $\mu\text{A}$ )	Tan $\delta$ 100 Hz	Z 10 kHz ( $\Omega$ )	CATALOG NUMBER 2222 139 .....
63	2.2	14.3 × 6.2 × 6.9	19	3.3	0.09	25	68228
	3.3	14.3 × 6.2 × 6.9	23	3.4	0.09	21	68338
	4.7	14.3 × 6.2 × 6.9	28	3.6	0.09	17	68478
	10	14.3 × 7.6 × 8.2	48	4.3	0.08	8	68109
100	1.0	14.3 × 6.2 × 6.9	12	3.2	0.09	55	69108
	2.2	14.3 × 6.2 × 6.9	19	3.4	0.09	29	69228
	3.3	14.3 × 7.6 × 8.2	27	3.7	0.08	17	69338
	4.7	14.3 × 7.6 × 8.2	33	3.9	0.08	11	69478

<b>ADDITIONAL ELECTRICAL DATA</b>		
PARAMETER	CONDITIONS	VALUE
<b>Voltage</b>		
Surge voltage for short periods		$U_s \leq 1.15 \times U_R$
Reverse voltage		$U_{rev} \leq 1 \text{ V}$
<b>Current</b>		
Leakage current	after 1 minute at $U_R$	$I_{L1} \leq 0.02 C_R \times U_R + 3$
	after 5 minute at $U_R$	$I_{L5} \leq 0.002 C_R \times U_R + 3 \mu\text{A}$
<b>Inductance</b>		
Equivalent series inductance (ESL)	nominal case size 14.3 × 6.2 × 6.9 mm	typ. 18 nH
	nominal case size 14.3 × 7.6 × 8.2 mm	typ. 28 nH
<b>Resistance</b>		
Equivalent series resistance (ESR)	calculated from tan $\delta_{max}$ and $C_R$ (see Table 4)	$ESR = \tan \delta / 2\pi f C_R$

**CAPACITANCE (C)**

 $C_0$  = capacitance at 20°C, 100Hz.

Fig.7 Typical multiplier of capacitance as a function of ambient temperature.

 $C_0$  = capacitance at 20°C, 100Hz.

 $T_{amb} = 20^\circ\text{C}$ 

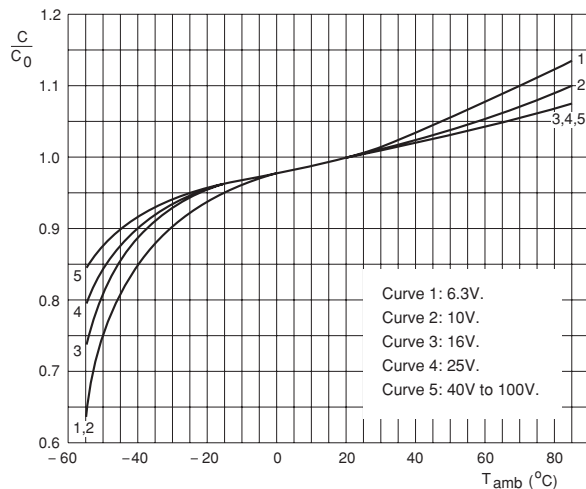
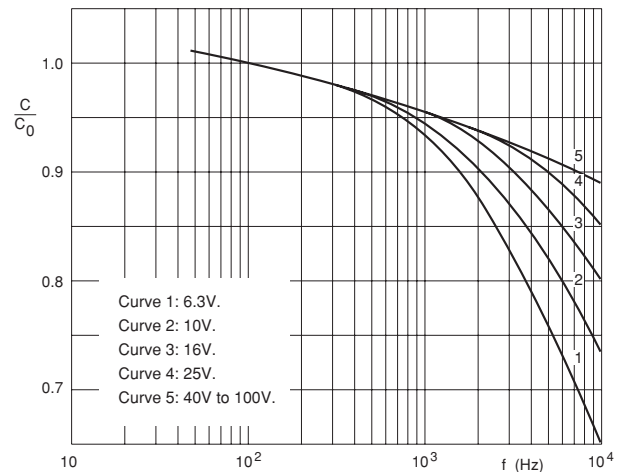
Fig.8 Typical multiplier of capacitance as a function of frequency.



**RIPPLE CURRENT AND USEFUL LIFE**

CCC206

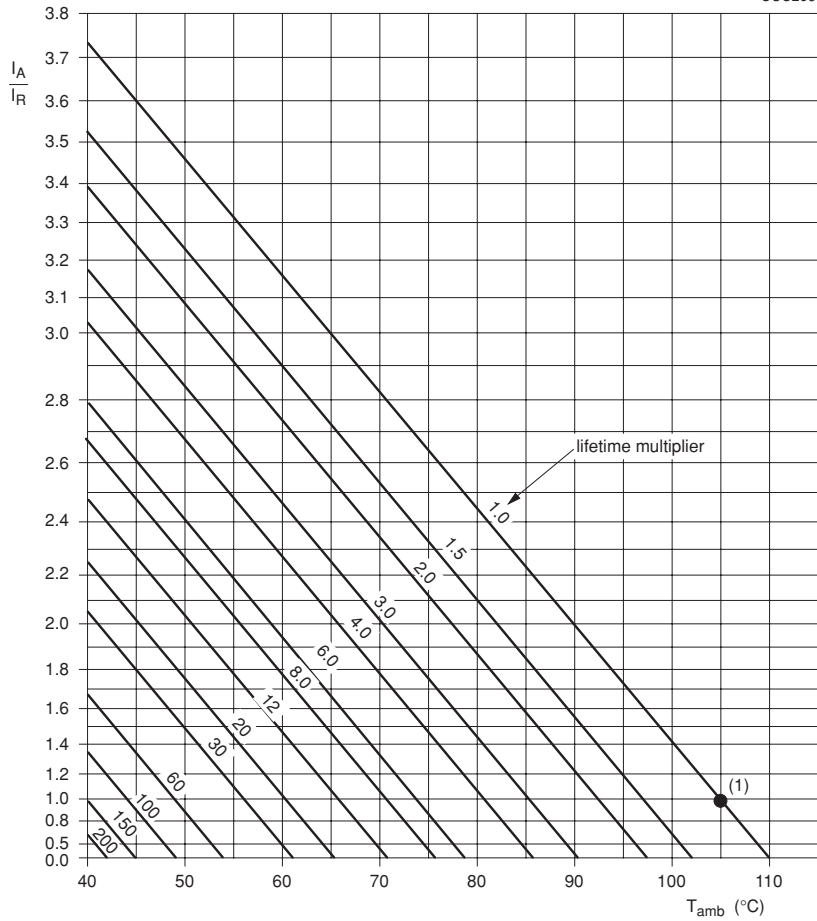

$I_A$  = actual ripple current at 100 Hz.  
 $I_R$  = rated ripple current at 100 Hz, 105°C.  
 (1) Useful life at 105°C and  $I_R$  applied: 2000 hours.

Fig.9 Multiplier of useful life as a function of ambient temperature and ripple current load.

Table 5

MULTIPLIER OF RIPPLE CURRENT ( $I_R$ ) AS A FUNCTION OF FREQUENCY			
FREQUENCY (Hz)	$I_R$ MULTIPLIER		
	$U_R = 6.3$ to $16$ V	$U_R = 25$ to $50$ V	$U_R = 63$ to $100$ V
50	0.95	0.90	0.85
100	1.00	1.00	1.00
300	1.07	1.12	1.20
1000	1.12	1.20	1.30
3000	1.15	1.25	1.35
$\geq 10000$	1.20	1.30	1.40



Table 6

<b>TEST PROCEDURES AND REQUIREMENTS</b>			
<b>TEST</b>		<b>PROCEDURE (quick reference)</b>	<b>REQUIREMENTS</b>
<b>NAME OF TEST</b>	<b>REFERENCE</b>		
Mounting	IEC 60384-18, subclause 4.3	shall be performed prior to tests mentioned below; reflow or (double-) wave soldering; for maximum temperature load refer to chapter "Mounting"	$\Delta C/C: \pm 5\%$ $\tan \delta \leq \text{spec. limit}$ $I_{L5} \leq \text{spec. limit}$
Endurance	IEC 60384-18/ CECC 32300, subclause 4.15	$T_{\text{amb}} = 105\text{ }^{\circ}\text{C}$ ; $U_R$ applied; 1000 hours	$U_R \leq 6.3\text{ V } \Delta C/C: +15/-30\%$ $U_R \geq 10\text{ V } \Delta C/C: \pm 15\%$ $\tan \delta \leq 1.3 \times \text{spec. limit}$ $Z \leq 2 \times \text{spec. limit}$ $I_{L5} \leq \text{spec. limit}$
Useful life	CECC 30301, subclause 1.8.1	$T_{\text{amb}} = 105\text{ }^{\circ}\text{C}$ ; $U_R$ and $I_R$ applied; 2000 hours	$U_R \leq 6.3\text{ V } \Delta C/C: +45/-50\%$ $U_R \geq 10\text{ V } \Delta C/C: \pm 45\%$ $\tan \delta \leq 3 \times \text{spec. limit}$ $Z \leq 3 \times \text{spec. limit}$ $I_{L5} \leq \text{spec. limit}$ no short or open circuit total failure percentage: $\leq 1\%$
Shelf life (storage at high temperature)	IEC 60384-18/ CECC 32300, subclause 4.17	$T_{\text{amb}} = 105\text{ }^{\circ}\text{C}$ ; no voltage applied; 500 hours after test: $U_R$ to be applied for 30 minutes, 24 to 48 hours before measurement	for requirements see 'Endurance test' above